

LOW ENERGY LED LIGHTING SYSTEM

Our new low energy LED lighting system is designed to be maintenance free. In the rare event of a failure, the LED units and transformer can be replaced (we recommend this is done by a competent person - instructions and guidance for engineers is available from the Service Department).

BASIC FAULT FINDING

Loss of cooling- Check power supply

- Check thermostat is correctly set
- Check product is not forcing grill on to circulation fan stopping rotation and air circulation
- Check gasket is sealing properly

Loss of lamp - See LED instructions above

The guarantee shall not cover any fault or defect caused by:

Parts not assembled in accordance with the instructions of the manufacturer
Careless operating, handling and misuse and/or lack of maintenance
External sources such a weather or transit damage (except where reported at time of delivery)

Repairs or alterations carried out by unauthorised parties or agents
Normal wear and tear including door gaskets and any damage caused by harsh cleaning materials

Damage caused by the use of parts and accessories other than those produced or recommended by the manufacturer

The fitting of replacement parts will not extend the period of guarantee.

OSBORNE REFRIGERATORS LTD

Rose Green Road

Bognor Regis

PO21 3EG

service@osborne-ref.co.uk

www.osborne-ref.co.uk

Tel +44(0)1243 267711



© 2022 Osborne Refrigerators Ltd

INSTALLATION AND USER MANUAL

PASS-THROUGH CHILLERS

276E / 605E / 7050

INTRODUCTION

This refrigerated cabinet is designed to store wine, beer and food conveniently and efficiently. With a little care, as described in this manual, it should give a long and trouble free life.

UNPACKING

Check the cabinet for obvious signs of damage while unwrapping, and contact your supplier if you are concerned about its condition. If the cabinet has been stored horizontally in transit, allow it to stand upright for an hour before plugging power cord into supply.

ELECTRICAL CONNECTION

The cabinet is complete with a factory-fitted fused plug suitable for a 13amp socket outlet. This appliance **must** be earthed.

LOCATION

Do not site the cabinet near a source of heat, such as a boiler or radiator, or in direct sunlight. This will conserve energy and reduce running costs. Do not place the cabinet on uneven or thick carpeted floors - only a solid surface ensures unrestricted air flow around the refrigeration system. Install the cabinet on a level surface - an uneven surface can increase vibration and affect alignment of doors. The cabinet should be vertical or leaning fractionally backwards - it **must not** lean forward.

RECOMMENDED OPERATION

Once the unit is stocked and in use, leave the cabinet to run continuously. If the unit is to be taken out of commission for a period of time, switch off at the mains and prop the door open to allow air to circulate.

DIGITAL TEMPERATURE CONTROLLER

See fig 1. To adjust the temperature, press the "set" button until the display blinks. Push the up or down buttons to increase or decrease the required temperature. Push the "set" button again to fix the temperature.

When the cabinet is defrosting, "dF" will show on the display. "E0" and "E1" are error codes indicating a fault with the temperature probes. In the event of an error code being displayed, contact your supplier.

SHELF CLIPS

Please ensure that the shelf clips are installed the correct way up (see fig 2). They will not support a loaded shelf if they are the wrong way up and damage will be done to the cabinet.

CLEANING THE CONDENSER

A clean condenser will give more efficient running and longer cabinet life. Cleaning the condenser requires no specialist knowledge or equipment and should be carried out regularly. The removable condenser grille(s) are at the front of the cabinet (see fig 3). They are sited on the left for model 276E, on the right for model 605E and both grilles need removing on model 7050. Firstly, pull them away from the front of the chiller and you will see the condenser behind. Simply use a brush or vacuum cleaner to remove dust and fluff from the condenser. The rate at which the condenser collects dust depends greatly on site conditions. A nearby external door to a busy roadway, building work in the area or even fluffy carpets will create more material to catch in the condenser.

Important - If the condenser becomes blocked it will seriously effect the cooling performance of the cabinet. Prolonged blockage can lead to overheating, inefficient running and eventually failure of the refrigeration system so check the condenser regularly.

ALWAYS KEEP THE CONDENSER CLEAN

GENERAL CLEANING

Before use, and periodically thereafter, clean the inside of the cabinet with a soft cloth and a solution of one teaspoon of Bicarbonate of Soda (Sodium Bicarbonate), to one litre (1¾ pints) of warm water. Rinse with clean water and dry thoroughly. Clean the outside of the cabinet as necessary with mild detergent and warm water. Rinse with clean water and dry thoroughly. Ensure that the door seal and the front edge of the cabinet are thoroughly cleaned. **Do not** use abrasives of any kind on the cabinet.

DOOR GASKETS

Wine, beer and other sugary liquids spilt on the gasket will cause the door to stick which will tear the gasket. Please clean regularly as instructed above. If the door gasket requires replacement, it is usually easier to remove the door (see fig 4) and lay it down to avoid the glass unit falling out. Simply remove all the screws from the retaining strips, remove strips and remove the gasket. Replace with a new gasket and reverse the above instructions.

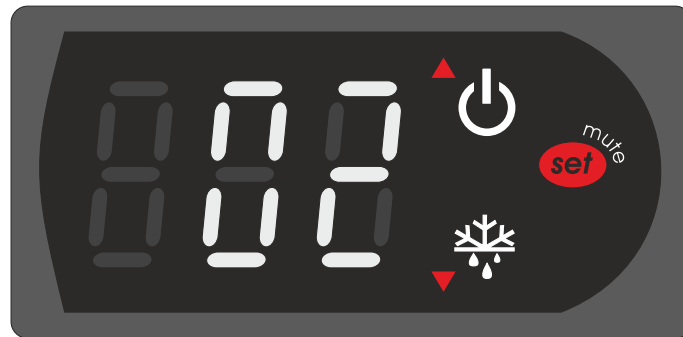

fig 1

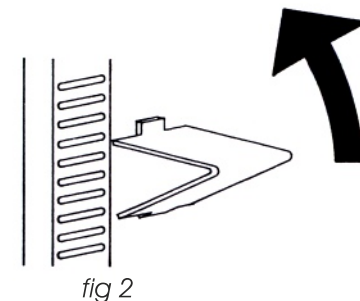

fig 2

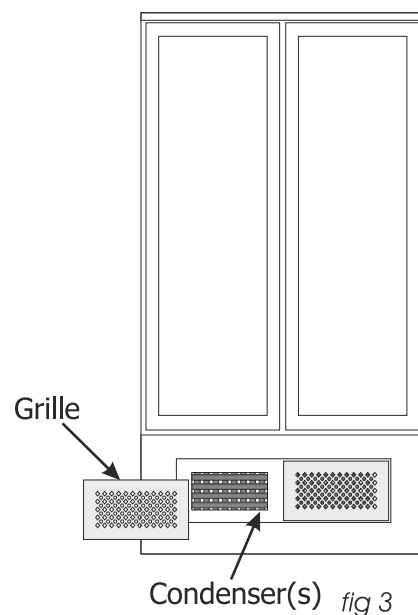

fig 3

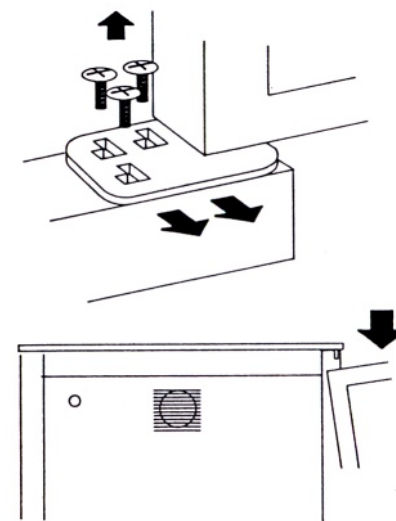

fig 4